

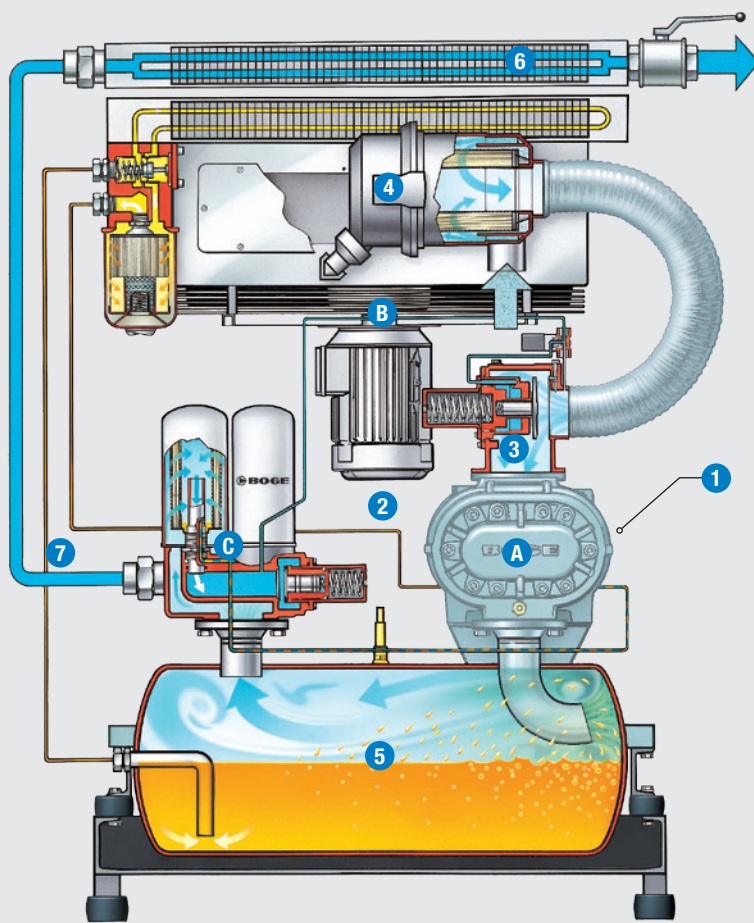

BOGE S series S-3



Top quality has surpassed itself again: The new generation BOGE S series.



Details of new generation:

- A** New BOGE efficiency airend
- B** New cooling fan design
- C** Optimised oil separation

Proven benefits of the BOGE S series:

- 1** Highly efficient IE3 motor
- 2** Intelligent cooling air circulation
- 3** Valveless oil circuit with multifunction suction regulator
- 4** Suction filter with micro paper element
- 5** Highly effective oil separation system with horizontal receiver
- 6** Self-sufficient cooling system with separate fan
- 7** Internal pipework made from steel tubing
- 8** Integrated switch cabinet
- 9** Maintenance-friendly design

Intelligent design provides an edge:

The BOGE S series wins you over with its sophisticated design concept, highest quality workmanship and maximum cost-efficiency. Each component is the culmination of decades of expertise by our engineers – giving it an edge is evident in everyday use.

The ideal lubricant for your BOGE S-3: BOGE SYPREM S.

The advantages:

- Fully synthetic coolant and lubricant
- Reduced oil vaporisation, therefore lower consumption and oil carryover into the compressed air system
- Longer service life: changing intervals of up to 9000 operating hours can be achieved
- Viscosity index 55 for optimal temperature characteristics and wide operating temperature range
- Prevents deposits from forming, thus increases service life of compression stage and filtration media

The use of BOGE SYPREM S makes it possible to increase the guarantee period to five years within the framework of the BOGE best**cair** guarantee programme. Further information is available at: www.boge.com.

One of the best has been improved upon: The S series has set standards in efficient and reliable compressed air production. Now, BOGE has made one of the best screw compressor ranges on the market even better. While retaining the proven design philosophy, the efficiency, smooth running properties and the sound pressure levels have been significantly optimised. You can look forward to the best S series of all time!



The depicted machine is the super-silenced version



EVEN MORE EFFICIENT

The new generation BOGE S series has the most efficient airend ever employed by BOGE – the BOGE effilence. Included as standard in every machine in the S-3 series, BOGE's effilence enhances the increased air delivery and improved oil separation system to the high level of efficiency achieved by the new compressor generation.

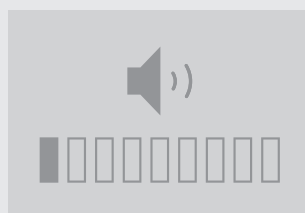

EVEN QUIETER

As well as the innovative BOGE effilence airend, the new designed fan makes the BOGE S-3 series quieter than ever. Its speed has been halved resulting in reduced noise levels – while the cooling air has been improved at the same time to provide a consistent cooling performance. The result speaks for itself: the quietest S series of all time!



PROVEN CONTROL

The compressor control in the standard version uses a familiar and intuitive FOCUS control which provides numerous monitoring and control features that allows connection to master control system.



PROVEN DESIGN

Irrespective of the modification incorporated, the proven design of the S series has still been retained: providing the advantages of the efficient cooling air circulation, the effective optimised oil separation system with a horizontal receiver and the premium quality of one of the most reliable screw compressors on the market.

BOGE Model	Max. pressure**		Effective free air delivery*		Motor power				Dimensions ¹⁾	Dimensions ²⁾	Com-pressed air outlet	Weight silenced kg	Weight super silenced kg
					Main drive		Fan motor		silenced W x D x H	super silenced W x D x H			
	bar	psig	m ³ /min	cfm	kW	HP	kW	HP	mm	mm			
S 31-3	7.5	110	4.00	142	22	30	0.75	1.0	1615x990x1450	–	G 1¼	750	–
S 31-3	8	115	3.88	138	22	30	0.75	1.0	1615x990x1450	–	G 1¼	750	–
S 31-3	10	150	3.35	119	22	30	0.75	1.0	1615x990x1450	–	G 1¼	750	–
S 31-3	13	190	2.73	97	22	30	0.75	1.0	1615x990x1450	–	G 1¼	750	–
S 40-3	7.5	110	5.47	194	30	40	0.75	1.0	1615x990x1450	–	G 1¼	842	–
S 40-3	8	115	5.31	188	30	40	0.75	1.0	1615x990x1450	–	G 1¼	842	–
S 40-3	10	150	4.77	169	30	40	0.75	1.0	1615x990x1450	–	G 1¼	842	–
S 40-3	13	190	3.91	139	30	40	0.75	1.0	1615x990x1450	–	G 1¼	842	–
SD 40-3	7.5	110	5.47	194	30	40	0.75	1.0	1615x990x1730	–	G 1¼	970	–
SD 40-3	8	115	5.31	188	30	40	0.75	1.0	1615x990x1730	–	G 1¼	970	–
SD 40-3	10	150	4.77	169	30	40	0.75	1.0	1615x990x1730	–	G 1¼	970	–
SD 40-3	13	190	3.91	139	30	40	0.75	1.0	1615x990x1730	–	G 1¼	970	–
S 40-3 BLUEKAT	7.5	110	5.47	194	30	40	0.75	1.0	2258x960x1955	–	G 1¼	1100	–
S 40-3 BLUEKAT	8	115	5.31	188	30	40	0.75	1.0	2258x960x1955	–	G 1¼	1100	–
S 40-3 BLUEKAT	10	150	4.77	169	30	40	0.75	1.0	2258x960x1955	–	G 1¼	1100	–
S 40-3 BLUEKAT	13	190	3.91	139	30	40	0.75	1.0	2258x960x1955	–	G 1¼	1100	–
S 50-3	7.5	110	6.64	235	37	50	1.5	2.0	1615x990x1450	1615x990x1950	G 1¼	843	873
S 50-3	8	115	6.45	228	37	50	1.5	2.0	1615x990x1450	1615x990x1950	G 1¼	843	873
S 50-3	10	150	5.77	204	37	50	1.5	2.0	1615x990x1450	1615x990x1950	G 1¼	843	873
S 50-3	13	190	4.92	174	37	50	1.5	2.0	1615x990x1450	1615x990x1950	G 1¼	843	873
SD 50-3	7.5	110	6.64	235	37	50	1.5	2.0	1615x990x1730	1615x990x1950	G 1¼	971	1001
SD 50-3	8	115	6.45	228	37	50	1.5	2.0	1615x990x1730	1615x990x1950	G 1¼	971	1001
SD 50-3	10	150	5.77	204	37	50	1.5	2.0	1615x990x1730	1615x990x1950	G 1¼	971	1001
SD 50-3	13	190	4.92	174	37	50	1.5	2.0	1615x990x1730	1615x990x1950	G 1¼	971	1001
S 50-3 BLUEKAT	7.5	110	6.64	235	37	50	1.5	2.0	–	2258x960x1955	G 1¼	–	1320
S 50-3 BLUEKAT	8	115	6.45	228	37	50	1.5	2.0	–	2258x960x1955	G 1¼	–	1320
S 50-3 BLUEKAT	10	150	5.77	204	37	50	1.5	2.0	–	2258x960x1955	G 1¼	–	1320
S 50-3 BLUEKAT	13	190	4.92	174	37	50	1.5	2.0	–	2258x960x1955	G 1¼	–	1320
S 60-3	7.5	110	7.52	266	45	60	1.5	2.0	1615x990x1450	1615x990x1950	G 1¼	994	1024
S 60-3	8	115	7.30	258	45	60	1.5	2.0	1615x990x1450	1615x990x1950	G 1¼	994	1024
S 60-3	10	150	6.54	231	45	60	1.5	2.0	1615x990x1450	1615x990x1950	G 1¼	994	1024
S 60-3	13	190	5.60	198	45	60	1.5	2.0	1615x990x1450	1615x990x1950	G 1¼	994	1024
SD 60-3	7.5	110	7.52	266	45	60	1.5	2.0	1615x990x1730	1615x990x1950	G 1¼	1122	1152
SD 60-3	8	115	7.30	258	45	60	1.5	2.0	1615x990x1730	1615x990x1950	G 1¼	1122	1152
SD 60-3	10	150	6.54	231	45	60	1.5	2.0	1615x990x1730	1615x990x1950	G 1¼	1122	1152
SD 60-3	13	190	5.60	198	45	60	1.5	2.0	1615x990x1730	1615x990x1950	G 1¼	1122	1152
SF 60-3	7.5	110	1.63 - 7.52	58 - 266	45	60	1.5	2.0	1615x990x1450	1615x990x1950	G 1¼	1057	1087
SF 60-3	8	115	1.58 - 7.30	56 - 258	45	60	1.5	2.0	1615x990x1450	1615x990x1950	G 1¼	1057	1087
SF 60-3	10	150	1.43 - 6.53	51 - 231	45	60	1.5	2.0	1615x990x1450	1615x990x1950	G 1¼	1057	1087
SF 60-3	13	190	1.19 - 5.67	43 - 201	45	60	1.5	2.0	1615x990x1450	1615x990x1950	G 1¼	1057	1087
SDF 60-3	7.5	110	1.63 - 7.52	58 - 266	45	60	1.5	2.0	1615x990x1730	1615x990x1950	G 1¼	1122	1152
SDF 60-3	8	115	1.58 - 7.30	56 - 258	45	60	1.5	2.0	1615x990x1730	1615x990x1950	G 1¼	1122	1152
SDF 60-3	10	150	1.43 - 6.53	51 - 231	45	60	1.5	2.0	1615x990x1730	1615x990x1950	G 1¼	1122	1152
SDF 60-3	13	190	1.19 - 5.67	43 - 201	45	60	1.5	2.0	1615x990x1730	1615x990x1950	G 1¼	1122	1152
S 61-3	7.5	110	8.09	286	45	60	1.5	2.0	1995x1065x1455	1995x1065x1950	G 1½	1180	1230
S 61-3	8	115	7.85	278	45	60	1.5	2.0	1995x1065x1455	1995x1065x1950	G 1½	1180	1230
S 61-3	10	150	7.10	251	45	60	1.5	2.0	1995x1065x1455	1995x1065x1950	G 1½	1180	1230
S 61-3	13	190	6.03	213	45	60	1.5	2.0	1995x1065x1455	1995x1065x1950	G 1½	1180	1230
SD 61-3	7.5	110	8.09	286	45	60	1.5	2.0	1995x1065x1950	1995x1065x1950	G 1½	1330	1380
SD 61-3	8	115	7.85	278	45	60	1.5	2.0	1995x1065x1950	1995x1065x1950	G 1½	1330	1380
SD 61-3	10	150	7.10	251	45	60	1.5	2.0	1995x1065x1950	1995x1065x1950	G 1½	1330	1380
SD 61-3	13	190	6.03	213	45	60	1.5	2.0	1995x1065x1950	1995x1065x1950	G 1½	1330	1380
S 75-3	7.5	110	10.18	360	55	75	2.2	3.0	1995x1065x1455	1995x1065x1950	G 1½	1260	1310
S 75-3	8	115	9.88	349	55	75	2.2	3.0	1995x1065x1455	1995x1065x1950	G 1½	1260	1310
S 75-3	10	150	9.04	320	55	75	2.2	3.0	1995x1065x1455	1995x1065x1950	G 1½	1260	1310
S 75-3	13	190	7.45	264	55	75	2.2	3.0	1995x1065x1455	1995x1065x1950	G 1½	1260	1310
SD 75-3	7.5	110	10.18	360	55	75	2.2	3.0	1995x1065x1950	1995x1065x1950	G 1½	1430	1480
SD 75-3	8	115	9.88	349	55	75	2.2	3.0	1995x1065x1950	1995x1065x1950	G 1½	1430	1480
SD 75-3	10	150	9.04	320	55	75	2.2	3.0	1995x1065x1950	1995x1065x1950	G 1½	1430	1480
SD 75-3	13	190	7.45	264	55	75	2.2	3.0	1995x1065x1950	1995x1065x1950	G 1½	1430	1480

BOGE Model	Max. pressure**		Effective free air delivery *		Motor power				Dimensions ¹⁾ silenced WxDxH	Dimensions ²⁾ super silenced WxDxH	Com-pressed air outlet	Weight silenced kg	Weight super silenced kg
	bar	psig	m³/min	cfm	Main drive		Fan motor		mm	mm			
					kW	HP	kW	HP					
S 90-3	7.5	110	11.69	413	65	90	2.2	3.0	1995x1065x1455	1995x1065x1950	G 1½	1328	1378
S 90-3	8	115	11.35	401	65	90	2.2	3.0	1995x1065x1455	1995x1065x1950	G 1½	1328	1378
S 90-3	10	150	10.18	360	65	90	2.2	3.0	1995x1065x1455	1995x1065x1950	G 1½	1328	1378
S 90-3	13	190	8.87	314	65	90	2.2	3.0	1995x1065x1455	1995x1065x1950	G 1½	1328	1378
SD 90-3	7.5	110	11.69	413	65	90	2.2	3.0	1995x1065x1950	1995x1065x1950	G 1½	1498	1548
SD 90-3	8	115	11.35	401	65	90	2.2	3.0	1995x1065x1950	1995x1065x1950	G 1½	1498	1548
SD 90-3	10	150	10.18	360	65	90	2.2	3.0	1995x1065x1950	1995x1065x1950	G 1½	1498	1548
SD 90-3	13	190	8.87	314	65	90	2.2	3.0	1995x1065x1950	1995x1065x1950	G 1½	1498	1548
S 100-3	7.5	110	13.18	466	75	100	2.2	3.0	1995x1065x1455	1995x1065x1950	G 1½	1358	1408
S 100-3	8	115	12.80	452	75	100	2.2	3.0	1995x1065x1455	1995x1065x1950	G 1½	1358	1408
S 100-3	10	150	11.00	389	75	100	2.2	3.0	1995x1065x1455	1995x1065x1950	G 1½	1358	1408
S 100-3	13	190	9.53	337	75	100	2.2	3.0	1995x1065x1455	1995x1065x1950	G 1½	1358	1408
SD 100-3	7.5	110	13.18	466	75	100	2.2	3.0	1995x1065x1950	1995x1065x1950	G 1½	1528	1578
SD 100-3	8	115	12.80	452	75	100	2.2	3.0	1995x1065x1950	1995x1065x1950	G 1½	1528	1578
SD 100-3	10	150	11.00	389	75	100	2.2	3.0	1995x1065x1950	1995x1065x1950	G 1½	1528	1578
SD 100-3	13	190	9.53	337	75	100	2.2	3.0	1995x1065x1950	1995x1065x1950	G 1½	1528	1578
SF 100-3	7.5	110	3.00 - 13.18	106 - 466	75	100	2.2	3.0	2043x1065x1455	2043x1065x1950	G 1½	1388	1438
SF 100-3	8	115	2.91 - 12.80	103 - 452	75	100	2.2	3.0	2043x1065x1455	2043x1065x1950	G 1½	1388	1438
SF 100-3	10	150	2.58 - 11.00	92 - 389	75	100	2.2	3.0	2043x1065x1455	2043x1065x1950	G 1½	1388	1438
SF 100-3	13	190	2.09 - 9.53	74 - 337	75	100	2.2	3.0	2043x1065x1455	2043x1065x1950	G 1½	1388	1438
SDF 100-3	7.5	110	3.00 - 13.18	106 - 466	75	100	2.2	3.0	2043x1065x1950	2043x1065x1950	G 1½	1538	1588
SDF 100-3	8	115	2.91 - 12.80	103 - 452	75	100	2.2	3.0	2043x1065x1950	2043x1065x1950	G 1½	1538	1588
SDF 100-3	10	150	2.58 - 11.00	92 - 389	75	100	2.2	3.0	2043x1065x1950	2043x1065x1950	G 1½	1538	1588
SDF 100-3	13	190	2.09 - 9.53	74 - 337	75	100	2.2	3.0	2043x1065x1950	2043x1065x1950	G 1½	1538	1588
S 101-3	7.5	110	14.32	506	75	100	2.2	3.0	2366x1315x1760	2366x1315x2255	G 2½	2047	2107
S 101-3	8	115	13.90	491	75	100	2.2	3.0	2366x1315x1760	2366x1315x2255	G 2½	2047	2107
S 101-3	10	150	12.05	426	75	100	2.2	3.0	2366x1315x1760	2366x1315x2255	G 2½	2047	2107
S 101-3	13	190	11.10	392	75	100	2.2	3.0	2366x1315x1760	2366x1315x2255	G 2½	2047	2107
SD 101-3	7.5	110	14.32	506	75	100	2.2	3.0	2366x1315x1760	2366x1315x2255	G 2½	2213	2273
SD 101-3	8	115	13.90	491	75	100	2.2	3.0	2366x1315x1760	2366x1315x2255	G 2½	2213	2273
SD 101-3	10	150	12.05	426	75	100	2.2	3.0	2366x1315x1760	2366x1315x2255	G 2½	2213	2273
SD 101-3	13	190	11.10	392	75	100	2.2	3.0	2366x1315x1760	2366x1315x2255	G 2½	2213	2273
S 125-3	7.5	110	16.22	573	90	125	4.0	5.5	2366x1315x1760	2366x1315x2255	G 2½	2067	2127
S 125-3	8	115	15.75	557	90	125	4.0	5.5	2366x1315x1760	2366x1315x2255	G 2½	2067	2127
S 125-3	10	150	14.25	504	90	125	4.0	5.5	2366x1315x1760	2366x1315x2255	G 2½	2067	2127
S 125-3	13	190	11.80	417	90	125	4.0	5.5	2366x1315x1760	2366x1315x2255	G 2½	2067	2127
SD 125-3	7.5	110	16.22	573	90	125	4.0	5.5	2366x1315x1760	2366x1315x2255	G 2½	2233	2293
SD 125-3	8	115	15.75	557	90	125	4.0	5.5	2366x1315x1760	2366x1315x2255	G 2½	2233	2293
SD 125-3	10	150	14.25	504	90	125	4.0	5.5	2366x1315x1760	2366x1315x2255	G 2½	2233	2293
SD 125-3	13	190	11.80	417	90	125	4.0	5.5	2366x1315x1760	2366x1315x2255	G 2½	2233	2293
S 150-3	7.5	110	18.99	671	110	150	4.0	5.5	2366x1315x1760	2366x1315x2255	G 2½	2132	2192
S 150-3	8	115	18.44	652	110	150	4.0	5.5	2366x1315x1760	2366x1315x2255	G 2½	2132	2192
S 150-3	10	150	16.25	574	110	150	4.0	5.5	2366x1315x1760	2366x1315x2255	G 2½	2132	2192
S 150-3	13	190	14.25	504	110	150	4.0	5.5	2366x1315x1760	2366x1315x2255	G 2½	2132	2192
SD 150-3	7.5	110	18.99	671	110	150	4.0	5.5	2366x1315x1760	2366x1315x2255	G 2½	2298	2358
SD 150-3	8	115	18.44	652	110	150	4.0	5.5	2366x1315x1760	2366x1315x2255	G 2½	2298	2358
SD 150-3	10	150	16.25	574	110	150	4.0	5.5	2366x1315x1760	2366x1315x2255	G 2½	2298	2358
SD 150-3	13	190	14.25	504	110	150	4.0	5.5	2366x1315x1760	2366x1315x2255	G 2½	2298	2358
SF 150-3	7.5	110	4.78 - 19.00	169-671	110	150	4.0	5.5	2414x1315x1760	2414x1315x2255	G 2½	2200	2260
SF 150-3	8	115	4.64 - 18.44	164 - 652	110	150	4.0	5.5	2414x1315x1760	2414x1315x2255	G 2½	2200	2260
SF 150-3	10	150	4.27 - 16.25	151 - 574	110	150	4.0	5.5	2414x1315x1760	2414x1315x2255	G 2½	2200	2260
SF 150-3	13	190	2.97 - 14.25	105 - 504	110	150	4.0	5.5	2414x1315x1760	2414x1315x2255	G 2½	2200	2260
SDF 150-3	7.5	110	4.78 - 19.00	169-671	110	150	4.0	5.5	2414x1315x1760	2414x1315x2255	G 2½	2366	2426
SDF 150-3	8	115	4.64 - 18.44	164 - 652	110	150	4.0	5.5	2414x1315x1760	2414x1315x2255	G 2½	2366	2426
SDF 150-3	10	150	4.27 - 16.25	151 - 574	110	150	4.0	5.5	2414x1315x1760	2414x1315x2255	G 2½	2366	2426
SDF 150-3	13	190	2.97 - 14.25	105 - 504	110	150	4.0	5.5	2414x1315x1760	2414x1315x2255	G 2½	2366	2426

* Free air delivery for the complete package in accordance with ISO 1217, Appendix E, at 20°C ambient temperature and maximum pressure. Emitted sound pressure values from 64 dB(A) according to DIN EN ISO 2151:2009

**Max. pressure of the compressor, the 7.5 bar indications are to be provided as reference values. The machines are shipped standard in 8 bar.

¹⁾super-silenced on the intake side ²⁾super-silenced on the intake and on the exhaust air side

Efficiency on a large scale:

The **BOGE SLF**.



Effective FAD: 1.19 – 35.74 m³/min, 43 – 1262 cfm

Pressure range: 7.5 – 13 bar, 110 – 190 psig

Rated power: 22 – 200 kW, 30 – 270 HP



**Frequency control drive
and cooling fan +
integrated heat recovery:**
Your extra bonus in efficiency.

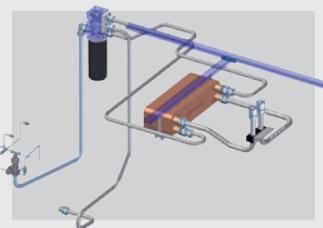

ABSOLUTELY DEMAND-ORIENTED

The frequency converter is primarily integrated to control motor and airend speeds in order to produce the momentary air demand requirement at the required pressure.

MAXIMUM EFFICIENCY

Frequency control is ideal where shift/production patterns create a fluctuating demand for compressed air or where there is a small storage volume or in a multiple installation for peak load operation. Built in frequency control continuously adjusts the volume flow to the actual demand ensuring minimised idling times and pressure fluctuations providing an energy efficient solution.

INTELLIGENT FAN CONTROL

From the S 61-3 up we offer variable cooling air flow via frequency-controlled fan as an option. It ensures that it only ever works as hard as necessary. These machines achieve a significant efficiency advantage.

HIGH EFFICIENCY

The centrepiece of the integrated DUOTHERM BPT heat exchanger is a plate heat exchanger through which passes hot oil around +85°C from the oil circuit. The counter-flow water passing through the heat exchanger is heated up to around +70°C – and can then be used as heating or production water.

Operating within the specific optimal range: In combination with the direct drive and frequency control, the SLF machines provide an extremely flexible system that adapts spontaneously to changes in the compressed air demand. If the pressure value changes, the air delivery is also synchronised automatically! This means that the machine supplies only the precise amount of compressed air that is actually needed at the time.

BOGE Model***	Max. pressure**		Effective free air delivery*		Motor power				Dimensions ¹⁾	Dimensions ²⁾	Compressed air outlet	Weight silenced kg	Weight super silenced kg
	bar	psig	m ³ /min	cfm	Main drive		Fan motor		silenced WxDxH	super silenced WxDxH			
					kW	HP	kW	HP	mm	mm			
SLF 30-3	7.5	110	1.25 - 3.94	45 - 140	22	30	0.75	1.0	1830x966x1450	–	G 1¼	775	–
SLF 30-3	8	115	1.20 - 3.87	43 - 137	22	30	0.75	1.0	1830x966x1450	–	G 1¼	775	–
SLF 30-3	10	150	on request	on request	22	30	0.75	1.0	1830x966x1450	–	G 1¼	775	–
SLF 30-3	13	190	on request	on request	22	30	0.75	1.0	1830x966x1450	–	G 1¼	775	–
SLDF 30-3	7.5	110	1.25 - 3.94	45 - 140	22	30	0.75	1.0	1830x966x1730	–	G 1¼	899	–
SLDF 30-3	8	115	1.20 - 3.87	43 - 137	22	30	0.75	1.0	1830x966x1730	–	G 1¼	899	–
SLDF 30-3	10	150	on request	on request	22	30	0.75	1.0	1830x966x1730	–	G 1¼	899	–
SLDF 30-3	13	190	on request	on request	22	30	0.75	1.0	1830x966x1730	–	G 1¼	899	–
SLF 40-3	7.5	110	1.30 - 5.48	46 - 194	30	40	0.75	1.0	1830x966x1450	–	G 1¼	845	–
SLF 40-3	8	115	1.30 - 5.31	46 - 188	30	40	0.75	1.0	1830x966x1450	–	G 1¼	845	–
SLF 40-3	10	150	1.30 - 4.75	46 - 168	30	40	0.75	1.0	1830x966x1450	–	G 1¼	845	–
SLF 40-3	13	190	1.26 - 4.21	45 - 149	30	40	0.75	1.0	1830x966x1450	–	G 1¼	845	–
SLDF 40-3	7.5	110	1.30 - 5.48	46 - 194	30	40	0.75	1.0	1830x966x1730	–	G 1¼	1055	–
SLDF 40-3	8	115	1.30 - 5.31	46 - 188	30	40	0.75	1.0	1830x966x1730	–	G 1¼	1055	–
SLDF 40-3	10	150	1.30 - 4.75	46 - 168	30	40	0.75	1.0	1830x966x1730	–	G 1¼	1055	–
SLDF 40-3	13	190	1.26 - 4.21	45 - 149	30	40	0.75	1.0	1830x966x1730	–	G 1¼	1055	–
SLF 40-3 BLUEKAT	7.5	110	1.30 - 5.48	46 - 194	30	40	0.75	1.0	2470x966x1955	–	G 1¼	1171	–
SLF 40-3 BLUEKAT	8	115	1.30 - 5.31	46 - 188	30	40	0.75	1.0	2470x966x1955	–	G 1¼	1171	–
SLF 40-3 BLUEKAT	10	150	1.30 - 4.75	46 - 168	30	40	0.75	1.0	2470x966x1955	–	G 1¼	1171	–
SLF 40-3 BLUEKAT	13	190	1.26 - 4.01	45 - 149	30	40	0.75	1.0	2470x966x1955	–	G 1¼	1171	–
SLF 51-3	7.5	110	2.35 - 7.35	83 - 260	37	50	1.1	1.5	2043x1065x1455	2043x1065x1950	G 1½	1250	1300
SLF 51-3	8	115	2.30 - 7.16	82 - 253	37	50	1.1	1.5	2043x1065x1455	2043x1065x1950	G 1½	1250	1300
SLF 51-3	10	150	2.25 - 6.43	80 - 228	37	50	1.1	1.5	2043x1065x1455	2043x1065x1950	G 1½	1250	1300
SLF 51-3	13	190	2.12 - 5.12	75 - 181	37	50	1.1	1.5	2043x1065x1455	2043x1065x1950	G 1½	1250	1300
SLF 61-3	7.5	110	2.40 - 8.19	85 - 290	45	60	1.5	2.0	2043x1065x1455	2043x1065x1950	G 1½	1380	1430
SLF 61-3	8	115	2.40 - 7.90	85 - 279	45	60	1.5	2.0	2043x1065x1455	2043x1065x1950	G 1½	1380	1430
SLF 61-3	10	150	2.30 - 7.00	82 - 248	45	60	1.5	2.0	2043x1065x1455	2043x1065x1950	G 1½	1380	1430
SLF 61-3	13	190	2.14 - 5.78	76 - 205	45	60	1.5	2.0	2043x1065x1455	2043x1065x1950	G 1½	1380	1430
SLF 75-3	7.5	110	2.25 - 9.80	80 - 347	55	75	2.2	3.0	2043x1065x1455	2043x1065x1950	G 1½	1498	1548
SLF 75-3	8	115	2.20 - 9.60	78 - 339	55	75	2.2	3.0	2043x1065x1455	2043x1065x1950	G 1½	1498	1548
SLF 75-3	10	150	2.10 - 8.50	75 - 301	55	75	2.2	3.0	2043x1065x1455	2043x1065x1950	G 1½	1498	1548
SLF 75-3	13	190	2.18 - 7.26	77 - 257	55	75	2.2	3.0	2043x1065x1455	2043x1065x1950	G 1½	1498	1548
SLF 101-3	7.5	110	5.10 - 14.19	181 - 502	75	100	3.0	4.0	2414x1315x1760	2414x1315x2255	G 2½	2112	2172
SLF 101-3	8	115	5.10 - 13.96	181 - 493	75	100	3.0	4.0	2414x1315x1760	2414x1315x2255	G 2½	2112	2172
SLF 101-3	10	150	4.94 - 12.25	175 - 433	75	100	3.0	4.0	2414x1315x1760	2414x1315x2255	G 2½	2112	2172
SLF 101-3	13	190	3.68 - 10.69	130 - 378	75	100	3.0	4.0	2414x1315x1760	2414x1315x2255	G 2½	2112	2172
SLF 125-3	7.5	110	4.96 - 16.01	176 - 566	90	125	4.0	5.5	2414x1315x1760	2414x1315x2255	G 2½	2162	2222
SLF 125-3	8	115	4.98 - 15.70	176 - 555	90	125	4.0	5.5	2414x1315x1760	2414x1315x2255	G 2½	2162	2222
SLF 125-3	10	150	4.93 - 14.93	175 - 528	90	125	4.0	5.5	2414x1315x1760	2414x1315x2255	G 2½	2162	2222
SLF 125-3	13	190	4.79 - 12.80	170 - 452	90	125	4.0	5.5	2414x1315x1760	2414x1315x2255	G 2½	2162	2222
SLF 221	7.5	110	6.65 - 29.06	235 - 1026	160	220	4.0	5.5	3145x1910x2145	3145x1910x2645	DN 100	4500	4600
SLF 221	8	115	6.46 - 28.21	228 - 996	160	220	4.0	5.5	3145x1910x2145	3145x1910x2645	DN 100	4500	4600
SLF 221	10	150	6.18 - 25.06	218 - 885	160	220	4.0	5.5	3145x1910x2145	3145x1910x2645	DN 100	4500	4600
SLF 221	13	190	5.46 - 20.36	193 - 719	160	220	4.0	5.5	3145x1910x2145	3145x1910x2645	DN 100	4500	4600
SLF 271	7.5	110	6.65 - 35.74	235 - 1262	200	270	7.5	10.0	3145x1910x2145	3145x1910x2645	DN 100	4700	4800
SLF 271	8	115	6.46 - 34.70	228 - 1225	200	270	7.5	10.0	3145x1910x2145	3145x1910x2645	DN 100	4700	4800
SLF 271	10	150	6.18 - 30.50	218 - 1077	200	270	7.5	10.0	3145x1910x2145	3145x1910x2645	DN 100	4700	4800
SLF 271	13	190	5.46 - 24.70	193 - 872	200	270	7.5	10.0	3145x1910x2145	3145x1910x2645	DN 100	4700	4800

* Free air delivery for the complete package in accordance with ISO 1217, Appendix E, at 20°C ambient temperature and maximum pressure. Emitted sound pressure values from 64 dB(A) according to DIN EN ISO 2151:2009

** Max. pressure of the compressor, the 7.5 bar indications are to be provided as reference values. The machines are shipped standard in 8 bar.

*** The SLF 221 and 271 machines belong to the S-2 series

¹⁾super-silenced on the intake side ²⁾super-silenced on the intake and on the exhaust air side

The new premium airend from BOGE: BOGE effilence is the most efficient air-end ever employed by BOGE. Its name stands for two of its hallmarks: efficient compression (efficiency) and incomparably quiet operation (silence). This wholly BOGE developed and built airend will guarantee highest standard state-of-the-art technology: take advantage now of a new level of efficiency!



BOGE effilence: The design benefits.

Extremely small blow hole

The very small radius of the secondary rotor teeth means that the blow hole is very small, thus ensuring high efficiency.

Axial suction

An axial suction that has been calculated with flow simulation software takes place right from the BS 102: for maximum intake and therefore higher volumetric efficiency.

Circumferential speeds

The speed design point has been optimised and is clearly lower when compared to previous stages. As a result, efficiency losses caused by splashing are reduced. The stages do not only offer a quieter operation, but also increased running-life, as the bearing service life depends on the size as well as on the rotations performed.

Very small manufacturing tolerances

Due to the low tolerances the stage has a long service life, is efficient and quiet. Efficiency losses through gap and blow hole are minimized; the rattling noise through backlash, particularly during no-load times, do not occur any more.

Flow-optimized outlet shape

The design is optimised for outlet pressures from 8 to 9 bar. This prevents overcompression and backflow that causes high losses.

Large bearings

The high-quality bearings have been selected in the largest possible size. This leads to a calculated service life twice as long as previous models.

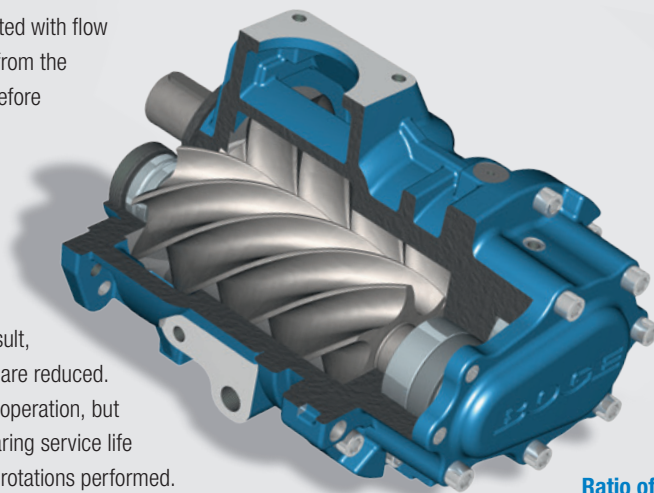

5:6 profile

The 5:6 screw profile of the rotors developed by BOGE (5 teeth primary rotor, 6 teeth secondary rotor) ensures low differential pressure between the chambers and therefore only minimal flow rate losses. Due to the innovative profile geometry with low leakage between the rotors, the blow hole is extremely small, ensuring a high volumetric efficiency.

Ratio of rotor length to rotor diameter

The rotor profile is optimally designed to achieve the ideal ratio of internal compression combined with the minimum rotor deflection.

Oil injection

The oil injection is designed for an optimum cooling effect and minimum splash losses.

BOGE Compressed Air Systems GmbH & Co. KG

P.O. Box 10 07 13 · 33507 Bielefeld
Otto-Boge-Straße 1-7 · 33739 Bielefeld
Fon +49 5206 601-0 · Fax +49 5206 601-200
info@boge.com · www.boge.com

